

Standard Features

- ▶ Emergency Power Off button with safety cover.
- ▶ Interactive Display Panel.



Galaxy 4000

40 – 75KVA

Uninterruptible Power Systems

Installation and User Manual

Galaxy 4000
40 – 75KVA
Uninterruptible Power Systems
Installation and User Manual

Revision History

Galaxy 4000 *Installation and User Manual* 86-173010-00
Revision: A00 ECN#: 004540 12/2005

Copyright © 2005 MGE UPS SYSTEMS, INC.
All rights reserved. Printed in U.S.A.

MGE UPS SYSTEMS, INC.
1660 Scenic Avenue
Costa Mesa, CA 92626
(714) 557-1636

Customer Care Center: 1-800-438-7373 (Hours: 24/7)

M G E
UPS SYSTEMS

www.mgeups.com

IMPORTANT SAFETY INSTRUCTIONS

SAVE THESE INSTRUCTIONS – This manual contains important instructions for Galaxy 4000 that must be followed during operation and maintenance of the equipment.



WARNING

Opening enclosures expose hazardous voltages. Always refer service to qualified personnel only.

ATTENTION

L'ouverture des cabinets expose des tensions dangereuses. Assurez-vous toujours que le service ne soit fait que par des personnes qualifiées.

WARNUNG!

Das Öffnen der Gehäuse legen gefährliche Spannungen bloss. Service sollte immer nur von qualifizierten Personal durchgeführt werden.



WARNING

As standards, specifications, and designs are subject to change, please ask for confirmation of the information given in this publication.

ATTENTION

Comme les normes, spécifications et produits peuvent changer, veuillez demander confirmation des informations contenues dans cette publication.

WARNUNG!

Normen, Spezifizierungen und Pläne unterliegen Änderungen. Bitte verlangen Sie eine Bestätigung über alle Informationen, die in dieser Ausgabe gemacht wurden.



NOTE

This equipment has been tested and found to comply with the limits for a Class A digital device, pursuant to part 15 of the FCC rules. These limits are designed to provide reasonable protection against harmful interference when the equipment is operated in a commercial environment.

This equipment generates, uses, and can radiate radio frequency energy and, if not installed and used in accordance with the instruction manual, may cause harmful interference to radio communications. Operation of this equipment in a residential area is likely to cause harmful interference in which case the user will be required to correct the interference at user's own expense.



WARNING

To reduce the risk of fire or electric shock, install in a controlled indoor environment free of conductive contaminants.

This equipment is intended only for installations in a RESTRICTED ACCESS LOCATION.

ATTENTION

Pour réduire le risque d'incendie ou d'électrocution, installer dans une enciente intérieure contrôlée en température et humidité et sans contaminants conducteurs.

Ce matériel est destiné seulement pour des installations dans un EMPLACEMENT RESTREINT D'ACCES.

WARNUNG!

Um die Gefahr von Feuer und elektrischem Schock zu reduzieren, muss das Gerät in einem temperatur – und feuchtigkeitskontrollierten Raum, frei von leitungsfähigen Verunreinigungen, installiert werden. Dieses Gerät ist nur für die Installation an einem Ort mit geingeschränkter Zugangserlaubnis vorgesehen.

Diese Ausrüstung ist nur für Anlagen in einem EINGESCHRÄNKTEN ZUGRIFF STANDORT bestimmt.

**WARNING**

HIGH LEAKAGE CURRENT. Earth connection essential before connecting supply.

ATTENTION

COURANT DE FUITE ELEVE. Raccordement a la terre indispensable avant le raccordement au reseau.

WARNUNG!

Hoher Ableitstrom Vor Inbetriebnahme Schutzleiterverbindung herstellen.

Certification Standards – Three Phase UPS

- ▶ IEC1004/ANSI C62.41 Standards for Surge Withstand Ability.
- ▶ FCC Part 15, Subpart J, Class A.
- ▶ UL/CUL 1778, Standards for Uninterruptible Power Supply Equipment.
- ▶ NEMA PE 1 - Uninterruptible Power Systems.
- ▶ NFPA 70 – National Electrical Code.
- ▶ ISO 9001.

Safety of Persons

- ▶ The UPS has its own internal power source (the battery). Consequently, the power terminals may be energized even if the UPS is disconnected from the AC power source.
- ▶ The UPS must be properly grounded.
- ▶ The battery supplied with the UPS contains small amounts of toxic materials. To avoid accidents, the directives listed below must be observed:
 - Never burn the battery (risk of explosion).
 - Do not attempt to open the battery (the electrolyte is dangerous for the eyes and skin).
 - Comply with all applicable regulations for the disposal of the battery.
 - Batteries constitute a danger (electrical shock, burns). The short-circuit current may be very high.
 - Precautions must be taken for all handling: remove watches, rings, bracelets and any other metal objects, use tools with insulated handles.
 - Do not lay tools or metal parts on top of batteries.

Product Safety

- ▶ Upstream protection must be installed and be easily accessible.
- ▶ The UPS can be disconnected from the AC power source by opening the input protective devices.
- ▶ UPS must be connected to a nearby power source that is easily accessible.
- ▶ Never block the ventilation openings of the UPS.
- ▶ The UPS must be installed in a controlled environment.

Special Precautions

- ▶ The UPS connection instructions and operation described in the manual must be followed in the indicated order.
- ▶ Check that the indications on the rating nameplate correspond to your AC powered system and to the actual electrical consumption of all the equipment to be connected to the UPS.
- ▶ Before and after the installation, if the UPS remains de-energized for a long period, the UPS must be energized for a period of 24 hours, at least once every 3 months (for a normal storage temperature less than 25°C). This charges the battery, thus avoiding possible irreversible damage.

Environment

This product has been designed to respect the environment; It does not contain any Chlorofluorocarbon (CFC) or Hydrochlorofluorocarbon (HCFC).

UPS recycling at the end of service life; MGE UPS SYSTEMS, INC. undertakes to recycle, by certified companies and in compliance with all applicable regulations, all UPS products recovered at the end of their service life (contact your MGE UPS SYSTEMS, INC. branch office).

Packing; UPS packing materials must be recycled in compliance with all applicable regulations.

WARNING: This product contains lead-acid batteries. Lead is a dangerous substance for the environment if it is not properly recycled by specialized companies.

section	description	page
	Revision History	i
	IMPORTANT SAFETY INSTRUCTIONS	ii
	Certification Standards - Three Phase UPS	iii
	Safety of Persons	iii
	Product Safety	iii
	Special Precautions	iii
	Environment	iii
	Symbol Usage	V
	Section Descriptions	V
Section 1	Introduction	
1.0	Scope	1 — 1
1.1	General Description	1 — 1
1.2	Major Components	1 — 2
1.3	Single Line Diagram	1 — 2
1.4	Galaxy 4000 Standard Cabinets	1 — 3
1.5	Preparation for Operation	1 — 3
1.6	Cabinet Placement	1 — 3
1.7	Heat Rejection and Air Flow	1 — 3
1.8	Cabinet Clearances	1 — 4
1.9	Conduit Plate Locations for Bottom Entry	1 — 4
1.10	Conduit Plate Locations for Top Entry	1 — 5
1.11	Preparation for Storage	1 — 6
Section 2	Setup and Installation	
2.0	Scope	2 — 1
2.1	Installation Steps	2 — 1
2.2	Environmental and Electrical Specifications	2 — 1
2.2.1	Environmental Recommendations	2 — 1
2.2.2	Electrical Specifications	2 — 2
2.3	Electrical Connections	2 — 2
2.3.1	UPS Connections	2 — 3
2.3.2	Main AC Input Connections	2 — 3
2.2.3	Bypass AC Input Connections (optional)	2 — 3
2.3.4	AC Output Connections	2 — 3
2.3.5	Battery Connections	2 — 4
2.3.6	Remote Emergency Power Off Connections	2 — 4
2.3.7	Battery Control Connections	2 — 4
2.3.8	External Maintenance Bypass Control Connections (optional)	2 — 5
2.3.9	Accessories Outlets	2 — 5

Section 2 Setup and Installation (continued)

section	description	page
2.4	Relay Communication Card Contacts	2 — 5
2.4.1	Relay Communication Card Connections	2 — 6
2.4.2	Characteristics of the Output Contacts	2 — 7
2.4.3	Characteristics of the Input Contacts	2 — 7

Section 3 Display Panel

3.0	Scope	3 — 1
3.1	Operator Interface Keys and Indicators	3 — 1
3.1.1	LED Indicator Functions	3 — 2
3.1.2	Screen Saver	3 — 2
3.1.3	Operational Summary Screen	3 — 2
3.2	Display Menu Structure	3 — 3
3.3	Main Menu Screen	3 — 4
3.4	Measurements	3 — 4
3.4.1	Battery Measurements Screen	3 — 4
3.4.2	Power Measurements Screen	3 — 5
3.4.3	Current Measurements Screen	3 — 5
3.4.4	Voltage Measurements Screen	3 — 6
3.4.5	Frequency Measurements Screen	3 — 6
3.4.6	Ratios Screen	3 — 6
3.5	Mimic Diagrams	3 — 7
3.6	Status Screen	3 — 7
3.7	Settings Screen	3 — 8
3.8	Commands Screen	3 — 9
3.9	Startup Procedure Screen	3 — 9

Section 4 Operation

4.0	Scope	4 — 1
4.1	Preparing for Startup	4 — 1
4.1.1	Pre-Startup Safety Check List	4 — 1
4.2	Normal Startup Procedure	4 — 3
4.3	Post Startup Safety Check List	4 — 4
4.4	Shutdown Procedure	4 — 4
4.5	Shutdown Using EPO	4 — 4
4.6	Recovery from EPO	4 — 4

Section 5 Maintenance

5.0	Scope	5 — 1
5.1	Servicing Batteries	5 — 1

Section 6 Warranty, Registration & Customer Support

description	page
MGE Warranty & Proprietary Rights for Three Phase Products6 – 1
MGE Standard Three Phase Warranty	
Proprietary Rights Statement	
Warranty and Product Registration6 – 2
User Information	
Product information	
Warranty Extension (Warranty+)	
MGE Customer Care Center6 – 3
Technical Support and Product Services	
Who To Contact	
Scheduling Field Service Engineer Support	
Return Policy for Repair of Three Phase Products (RGA)	
Caution: Record All Serial Numbers!6 – 4

Glossary

Reorder Form

Figures

figure	description	page
1-1	Galaxy 4000 UPS System	1 — 1
1-2	Galaxy 4000 UPS System - Single Line Diagram	1 — 2
1-3	Cabinet Placement, Airflow and Recommended Clearances	1 — 4
1-4	Configuration for Bottom Entry	1 — 5
1-5	Configuration for Top Entry	1 — 5
2-1	Typical Power Connections	2 — 4
2-3	Relay Communication Card	2 — 6
3-1	Display Panel Keys and Indicators	3 — 1
3-2	Screen Saver	3 — 2
3-3	Operational Summary screen	3 — 2
3-4	UPS Display Menu Structure	3 — 3
3-5	Main Menu screen	3 — 4
3-6	Battery Measurements screen	3 — 4
3-7	Power Measurements screen	3 — 5
3-8	Current Measurements screen	3 — 5
3-9	Voltage Measurements screen	3 — 6
3-10	Frequency Measurements screen	3 — 6
3-11	Ratios screen	3 — 6
3-12	Mimic Diagrams screen	3 — 7
3-13	Status screen	3 — 7
3-14	Settings screens	3 — 8
3-15	Commands screens	3 — 9
4-1	Galaxy 4000 Device Locations	4 — 2

Tables

table	description	page
1-1	Heat Rejection Data	1 — 4
2-1	Electrical Specifications for the Galaxy 4000	2 — 2
2-2	Relay Contacts (communication card)	2 — 5
3-1	Three LED Indicators	3 — 2

Symbol Usage

This manual uses five icon symbols with text to convey important information and tips.



WARNING

Indicates information provided to protect the user and service personnel against safety hazards and/or possible equipment damage.



CAUTION

Indicates information provided to protect the user and service personnel against possible equipment damage.



ELECTRICAL

Indicates information provided to protect the user and service personnel against possible electrical hazard and equipment damage.



IMPORTANT

Indicates information provided as an operating instruction, or as an operating tip.



NOTE

Indicates information provided as an operating tip or an equipment feature.

Section Descriptions

1 Introduction

Provides a general description of the Galaxy 4000 systems intended use, major components, mechanical and environmental specifications.

2 Setup and Installation

Guides the user through tools and equipment required for unpacking and performing connections required for initial installation. Included are the electrical specifications, environmental recommendations and connection details.

3 Display Panel

Describes the operator interface screens, keys, and mimic diagram.

4 Operation

Provides startup, shutdown, and normal operation of the Galaxy 4000 UPS. Included are pre and post startup safety checklists.

5 Maintenance

Describes maintenance and safety information on servicing batteries for the Galaxy 4000.

A **Glossary** provides definitions of abbreviations and terms used in this manual.

1.0 Scope

Provides a general description of the Galaxy 4000 systems intended use, major components, mechanical and environmental specifications.

1.1 General Description

The Galaxy 4000 is the world's first data center grade Uninterruptible Power Supply system designed specifically for mid-range enterprise level applications. The Galaxy 4000 family consists of units available in power ratings from 40 - 75KVA, and are optimized for compatibility with nonlinear computer-type loads.

By incorporating the Ultra High Availability Topology (UHAT), the Galaxy 4000 family of UPS systems are designed to provide the optimal level of reliability and to react to any power disturbance in an inherently safe way to protect the critical load. The Galaxy 4000 all-in-one design incorporates every feature into one compact cabinet, including a graphical user interface, power factor corrected input, and communication cards that support network based power management.

The Galaxy 4000 UPS and its auxiliary equipment are designed for installation in a room where humidity and temperature can be controlled.

The Galaxy 4000 UPS and auxiliary equipment is listed for safety by Underwriters Laboratories, Inc. (UL) under UL Standard 1778 – Uninterruptible Power Systems; and also listed by Underwriters Laboratories (CUL) under Canadian Standards Association (CSA) standard C22.107.

Figure 1-1: Galaxy 4000 UPS System.



1.2 Major Components

- Rectifier**

Converts AC input voltage to DC voltage. The rectifier uses IGBT (Insulated Gate Bipolar Transistor) power transistors and a Pulse Width Modulated (PWM) technique to provide input power factor correction and to minimize any harmonic reflected onto the input power lines.
- Inverter**

Converts DC voltage from the rectifier or from the batteries into AC output voltage to maintain the attached load. This module uses the IGBT technology to provide digital power quality.
- Static Switch**

Automatically supplies the attached load from the bypass source when the inverter is off.
- Battery System**

Stores energy for utilization by the inverter and attached load in the event that utility AC power is lost or is of unacceptable quality.

1.3 Single Line Diagram

During normal operation, the utility power (Main input) is supplied to the UPS rectifier. The rectifier converts the AC power to DC that is supplied to the inverter. The inverter converts the DC voltage to three-phase regulated AC voltage, which is supplied to the attached load.

During power failure conditions, the inverter is supplied by the stored energy in the battery system, and the load is powered continuously with no interruption.

The Galaxy 4000 UPS is designed for internal operation of 208VAC input and output. External batteries, and an output distribution panel may be contained in auxiliary cabinets similar in design to the Galaxy 4000 cabinet. Batteries or external maintenance bypass circuit breakers may also be contained in third party cabinets or wall mounted units.

Figure 1-2: Galaxy 4000 UPS System – Single Line Diagram.

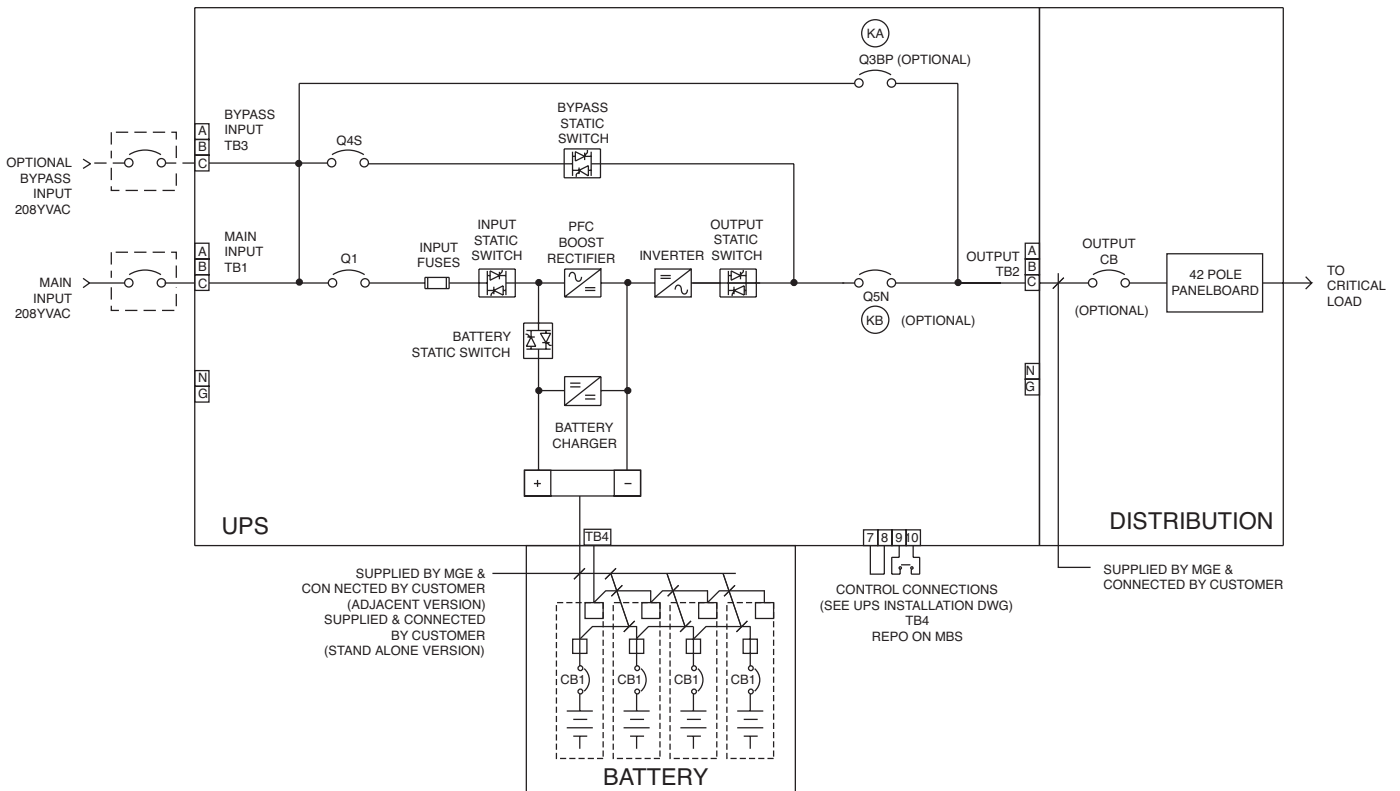

1.4 Galaxy 4000 Standard Cabinets

The Galaxy 4000 individual cabinet dimensions are:

- ▶ UPS cabinet: 72.1in (1831mm) H x 33.5in (851mm) W x 35.6in (904mm) D.
- ▶ External battery cabinet: 72.1in (1831mm) H x 26.5in (673mm) W x 33.5in (851mm) D **OR** –
- ▶ External battery cabinet: 72.1in (1831mm) H x 33.5in (851mm) W x 33.5in (851mm) D.
- ▶ Distribution cabinet: 72.1in (1831mm) H x 19.5in (495mm) W x 33.5in (851mm) D.

The UPS cabinet is designed to provide for top and bottom entry of the utility power feed. An output voltage of 208VAC is standard with the Galaxy 4000 and does not require any additional cabinetry. The complete list of additional cabinets that could be included with your Galaxy 4000 system are: external maintenance bypass wall cabinet, external battery cabinet, and distribution cabinet.

The external battery cabinets are provided in two different cabinet sizes depending upon the battery type selected. Up to four battery cabinets may be provided. The cabinets may be installed adjacent to the UPS or remotely and are designed for top and bottom entry. The distribution cabinet provides a 42 pole panelboard, with an optional submain circuit breaker. The cabinet is designed for top and bottom entry.

1.5 Preparation for Operation

Several items must be considered when preparing the Galaxy 4000 UPS system for operation.

First The UPS cabinet and its auxiliary cabinets must be arranged in the required configuration to insure that the interconnection cables are located in the correct adjacent cabinets.

Second The cabinets must be in a location that provides for proper air flow and heat rejection.

Third The room in which the Galaxy 4000 UPS system is located must maintain environmental conditions within recommended tolerances.

Forth All electrical connections must utilize the top or bottom conduit entries provided.

The following sections discuss these items in more detail.

1.6 Cabinet Placement

The complete UPS system may consist of one to three cabinets depending on the options selected. The UPS cabinet allows system options to be selected based on the application. When facing the Galaxy 4000 UPS from the front, the standard arrangement provides for any external batteries to be located on the right hand side, and the distribution cabinet to be located on the left hand side of the UPS. Refer to Figure 1-3 for cabinet placement.

1.7 Heat Rejection and Air Flow

The Galaxy 4000 UPS cabinets generate heat and exhaust air through the top portion of its enclosures. Air intake is through the bottom and front of the cabinet. All other cabinets are convection cooled. To assist you in planning for your HVAC needs, heat rejection data is provided in Table 1-1. The cabinet airflow and recommended top clearance are provided in Figure 1-3. The Galaxy 4000 is intended for use in an environment where control of temperature and humidity is provided.

Figure 1-3: Cabinet Placement, Airflow and Recommended Clearances.

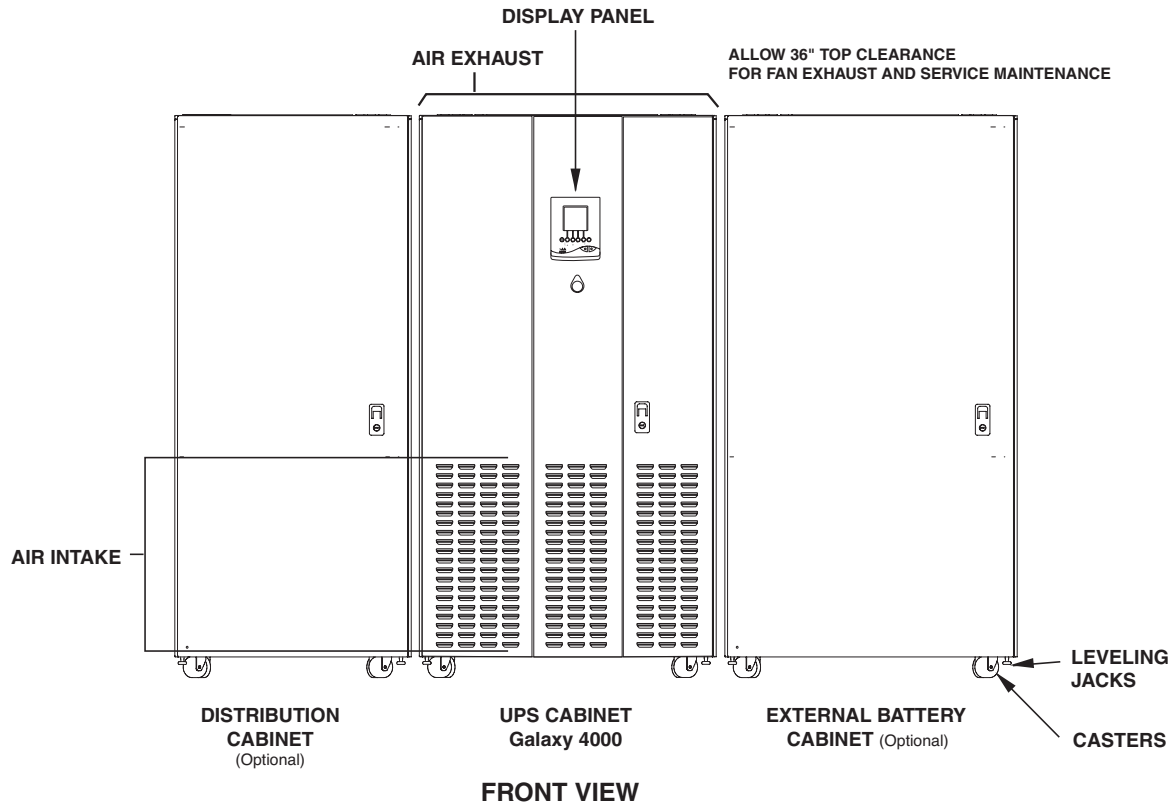

Table 1-1: Heat Rejection Data.

Heat Rejection Data @ 208/208VAC				
UPS cabinet	40KVA	50KVA	65KVA	75KVA
BTU/Hr	14,900	18,700	24,200	28,000



NOTE:

To provide for adequate ventilation, a minimum of 36 inches clearance should be maintained above the top of the Galaxy 4000 cabinet.

1.8 Cabinet Clearances

The Galaxy 4000 UPS cabinet top clearance of 36 inches for fan exhaust is recommended. Additionally, adequate space must be included in the front and top of each cabinet (approx. 36 inches) to allow the doors/panels of the cabinet to be opened for service and maintenance procedures.

For an installation where seismic requirements must be met, additional clearance at the side of the cabinet must be included to accommodate the seismic anchors. Contact your local MGE Sales Representative to order. See Figure 1-4.

1.9 Conduit Plate Locations for Bottom Entry

Cable entry through the bottom is the standard preferred design for the Galaxy 4000 UPS cabinet. The bottom entry conduit plate provides space for up to five (5) separate conduit entries. The plate is secured with screws which should be retained for the conduit plate after the power connections are made. See Figure 1-4 for the location of the bottom entry conduit plates.

Figure 1-4: Configuration for Bottom Entry.

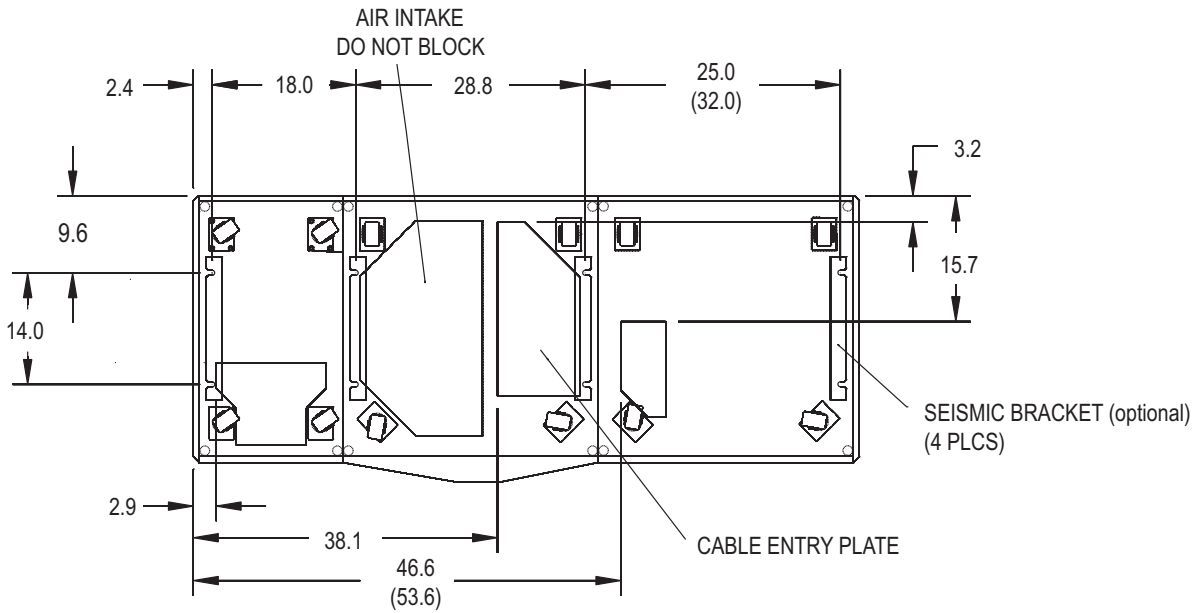

1.10 Conduit Plate Locations for Top Entry

The UPS cabinet for the Galaxy 4000 is capable of accepting power input and output cables through a top entry. The conduit plate on the top of the cabinet provides provisions for knockouts for conduit and is secured to the cabinet with screws. See Figure 1-5.

Figure 1-5: Configuration for Top Entry.

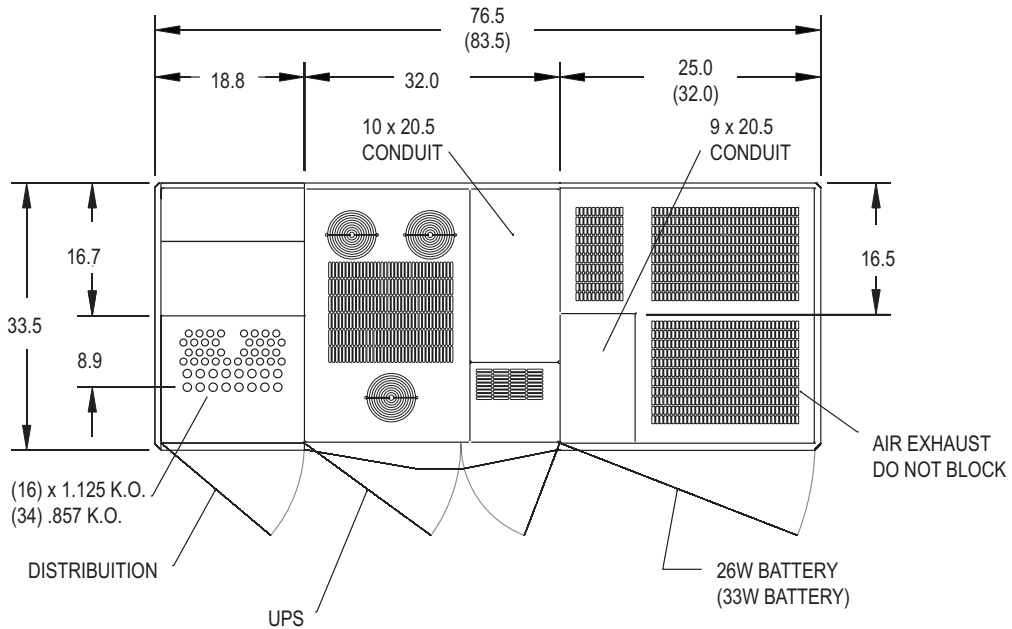

1.11 Preparation for Storage

If the equipment is to be stored prior to installation, it should be stored in a cool, dry, well-ventilated location that is protected against rain, splashing water, chemical agents, etc. The equipment should be covered with a tarpaulin or plastic wrapper to protect it against dust, dirt, paint, or other foreign materials. See the section of this manual titled "Environmental Recommendations" for recommended storage environmental conditions.



NOTE

Batteries should be stored no longer than three (3) months at 25°C (77°F) or lower prior to recharging. Exceeding the recommended ambient storage temperature will reduce battery back-up time and may adversely affect battery life.

Setup and Installation

2.0 Scope

Guides the user through tools and equipment required for unpacking and performing connections required for initial installation. Included are the electrical specifications, environmental recommendations and connection details.

2.1 Installation Steps

MGE recommends correct installation verification and unit startup to be performed by a qualified MGE Field Service Engineer.



CAUTION

Scheduling of the MGE Field Service Engineers typically should be done 7 to 10 days before they are required on-site. If the startup of the UPS is critical to maintaining your schedule, please call the MGE toll free telephone number at 1-800-438-7373 for assistance.

To insure a successful installation, each of these (5) steps should be followed in their correct sequence. Note that any unauthorized installation may cause damage to the UPS(s).

First steps by an on-site qualified Technical Engineer

- Step 1. Unpack and position the unit.
- Step 2. Connect the main (utility) power.
- Step 3. Connect the output to the load.

Final steps by MGE Field Service Engineer

- Step 4. Call MGE and wait for the MGE Field Service Engineer to approve the installation.
- Step 5. The MGE Field Service Engineer finalizes installation and the startup process.

2.2 Environmental and Electrical Specifications

2.2.1 Environmental Recommendations

Recommended environment 20° to 25°C (68° to 77°F.); 50% relative humidity; computer room or other temperature, and humidity-controlled environment.

Operating temperature 0° to 30°C (32° to 86°F) except battery.

Storage -20° to 40°C (-4° to 113°F) except battery.

Humidity up to 90% non-condensing (operating).

Altitude sea level to 3,000 feet without derating.

Acoustic noise 69 dBA at rated load as measured 5 feet from the front of the UPS cabinet.

2.2.2 Electrical Specifications

Table 2-1: Electrical Specifications for the Galaxy 4000.

Output Power Rating (0.8) PF	40KVA	50KVA	65KVA	75KVA
UPS Voltage (input/output)	208/208	208/208	208/208	208/208
Input/Output Requirements & Frequency	Three phase, Three wire + N + G, 60Hz			
Input Phase Rotation	A,B,C Clockwise			
Input Power Factor	>.98			
Input Current	102A	127A	166A	191A
Maximum Input Current(at low line -15%)	120A	150A	195A	225A
Bypass Current	111A	139A	180A	208A
Output Current	111A	139A	180A	208A
Battery Voltage	198 VDC End Voltage 240VDC Nominal 282VDC Max. Maintenance Voltage			
Max. Battery Current at Nominal Battery Voltage (240 VDC at 100% Load)	157A	196A	255A	294A
Max. Battery Current at Nominal End- Voltage (198 VDC at 100% Load)	190A	238A	309A	357A
Battery Disconnect Circuit Breaker Rating	250A		400A	
Input, Bypass, and Maintenance Bypass (optional) Switch Rating	150A		250A	
Input Fuse Rating	200A		300A	
Output Isolation Circuit Breaker Rating	175A		300A	

NOTE: Interrupted Transfer to Bypass Source:

If the bypass source is beyond the conditions stated below, the UPS will make an interrupted transfer (not more than 100 msec. in duration).

1. Bypass voltage greater than +15%, -15% from the UPS rated output voltage.
2. Bypass frequency greater than ± 2 Hz from the UPS rated output frequency.

2.3 Electrical Connections



CAUTION

Only an authorized electrical professional should access electrical connections. A severe shock hazard exists.

The ONLY user serviceable items in the Galaxy 4000 unit are:

- A. The main and bypass power connections.
- B. The load connection.
- C. Any cable connection to external or auxiliary modules.
- D. The communication card options.

The access method for connections made to the communication cards is clearly seen when the front right door to the Galaxy 4000 unit is opened. However, access to the main, bypass and load connections is made through the removal of the safety panel located in the lower right of the Galaxy 4000 (with the right door open). This safety panel is removed by first removing the screws securing the panel. It can then be removed by lifting the safety panel away from the unit.



CAUTION

Before making any electrical connections, verify that all battery disconnect circuit breakers (CB1) are in the "off" position. Customer-supplied upstream protective devices and distribution circuits should be OFF.

2.3.1 UPS Connections

Electrical connections and cabinet interconnection will vary depending upon the configuration and options selected with your Galaxy 4000 UPS system. Refer to the installation drawings supplied with your equipment.

Connecting Power Cable Connections:

To access the connection terminal blocks, open the right door to the Galaxy 4000 UPS. Remove the safety panel located in the lower right hand section of the unit. See Figure 2-1.

- a. The ground and neutral conductors must be connected to the ground and neutral busbars, respectively. The input and output neutral are connected at the neutral busbar.
- b. Connect the three conductors of the main AC source to terminal block TB1.
- c. If bypass source is present, connect the conductors of the bypass AC source to terminal block TB3. If bypass source is not present, verify jumpers in place between TB1 and TB3.
- d. Connect the three conductors supplying the load to terminal block TB2.
- e. Connect the battery conductors to the positive and negative busbars.
- f. Secure all cables with cable ties.
- g. Put all panels and covers back in place.

2.3.2 Main AC Input Connections

The connections to be made are the three phases, neutral, and ground cables from the utility AC power source to the UPS. The main AC input cables are terminated at the main input terminal block (TB1). See Figure 2-1.



IMPORTANT For single input (optional configuration), jumper cables are provided from terminal blocks TB1 to TB3.

2.3.3 Bypass AC Input Connections (optional)

The bypass AC input cables are terminated at the bypass input terminal block (TB3). This option provides a separate AC input source for bypass operation. See Figure 2-1.

2.3.4 AC Output Connections

The connections to be made are the three phases, neutral, and ground cables from the load to the UPS. The output cables are terminated at the output terminal block (TB2). See Figure 2-1.

Figure 2-1: Typical Power Connections.

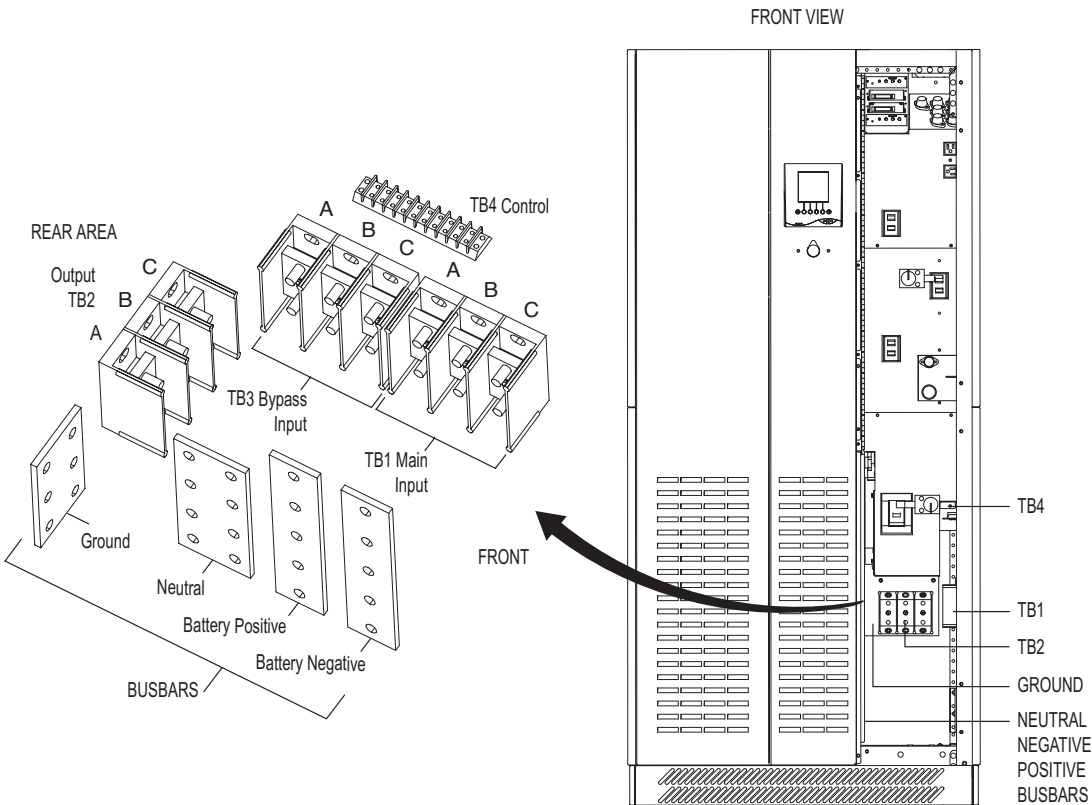

2.3.5 Battery Connections

The connections to be made are the positive, negative, and ground cables from the battery cabinet to the UPS. The battery cables are terminated at the positive, negative, and ground busbars. See Figure 2-1.

2.3.6 Remote Emergency Power Off Connections

The control connections are available for Remote Emergency Power Off (REPO) through a customer-supplied (normally closed) pushbutton. With REPO connected, the jumper on the REPO terminal blocks must be removed. See Figure 2-1.

1. Remove the jumper from terminal block TB4 located across terminals 7 and 8.
2. Connect the remote emergency power off NC contact to terminals 7 and 8.



IMPORTANT

The UPS is also equipped with a local Emergency Power Off (EPO) button on the front of the UPS cabinet. This switches all UPS critical power off. EPO or REPO should be used for emergency only!

2.3.7 Battery Control Connections

The battery control connections are made with the battery control cables from the external battery cabinet to the UPS terminal block TB4-1 to TB4-4. See Figure 2-1.

2.3.8 External Maintenance Bypass Control Connections (optional)

The external maintenance bypass (MBP) control connections are made with the MBP control cable from the external MBP to the UPS terminal block TB4-9 to TB4-10. See Figure 2-1.



ELECTRICAL **These wires carry HIGH VOLTAGE 120VAC.**

2.3.9 Accessories Outlets

The 120VAC outlets to be used on MGE authorized accessories only. The outlets total current not to exceed 2 amps.



CAUTION **Improper use of outlets may cause failure or damage to UPS.**

2.4 Relay Communication Card Contacts

The relay communication card contains six programmable dry contact outputs and two programmable dry inputs and is standard on the Galaxy 4000. The inputs and outputs are factory programmed according to functions listed in Table 2-2.

Table 2-2: Relay Contacts (communication card).

INPUTS	Factory Settings	Options (available on both contacts)
1.A	UPS ON	-Room temperature fault. -Transfer to bypass disabled. -Transfer to bypass disabled if bypass AC source out of tolerance. -Desynchronize UPS from bypass AC source.
1.B	UPS OFF	
OUTPUTS	Factory Settings	Options (available on all contacts)
1.1	General alarm	-Overload. -PFC Fault. -Inverter fault. -Charger fault. -Automatic bypass fault. -Bypass AC source out of tolerance. -Battery-temperature fault. -Emergency power off activated. -Battery circuit breaker(s) open. -Phase-sequence fault on normal or bypass. -AC source. -Blown fuse(s). -Transfer to bypass AC source disabled. -Operation in ECO mode. -UPS on bypass AC source.
1.2	Battery fault	
1.3	Load on UPS	
1.4	Load on automatic bypass	
1.5	Load on battery power	
1.6	Low battery warning	

The output contacts numbers for a second relay board installed will be 2.1 to 2.6. Contacts are of the NO (normally open) type. For dry contacts setting see section 3.7

**CAUTION**

Isolate and lock-out all power sources for this card before making connections. Never connect ELSV (extra low safety voltage) and non-ELSV circuits to the different outputs of the same card.

2.4.1 Relay Communication Card Connections

Refer to Figure 2-3 for relay communication card, cover and hardware details. See Figure 4-1 for communication card port location in the unit.

1. Remove the cover "3" secured by the screws "1".
2. Run the communication cables through the cable entry holes "4".
3. Connect the conductors to the input "6" and output "5" terminal blocks (refer to Figure 2-3 for a connection example.)
4. Put the cover back in place and secure it with the screws "1".
5. Tighten the screws "7" to clamp the cables.
6. Indicate the locations of the power sources on the labels.
7. Insert the card in its slot.
8. Secure the card with two screws "2".

Figure 2-3: Relay Communication Card.

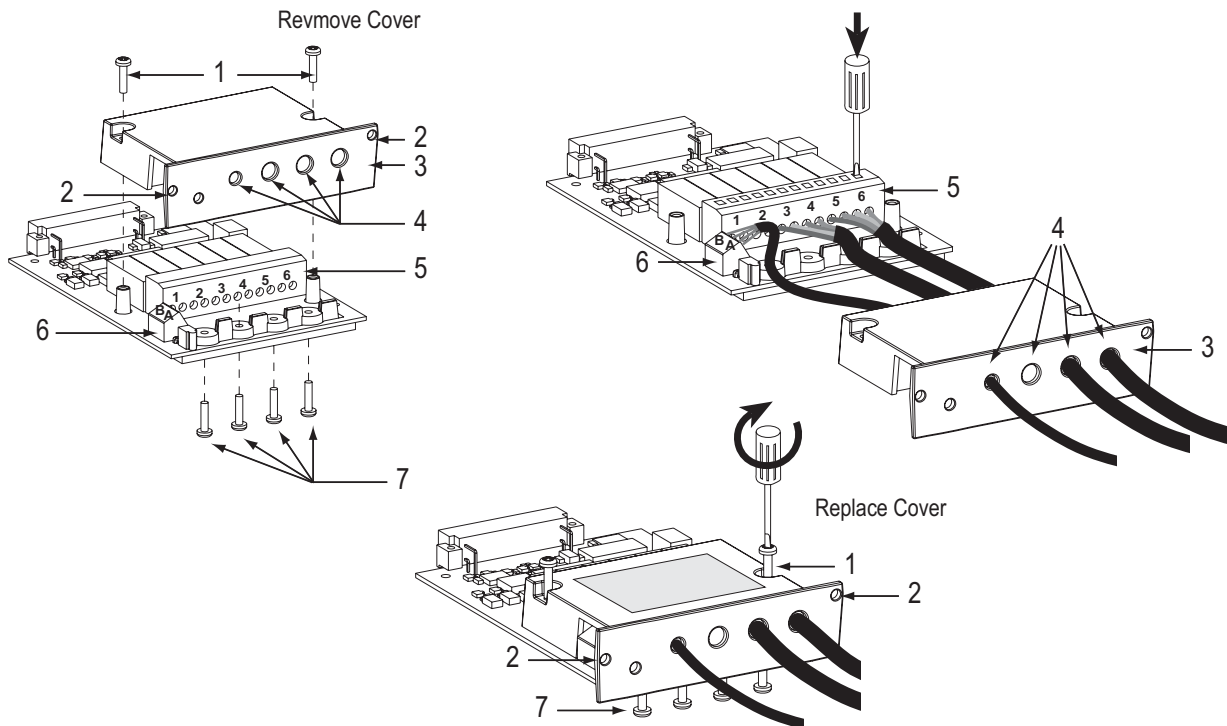

2.4.2 Characteristics of the Output Contacts

Relay Type	Normally Open.
Max. voltage	250VAC, 30VDC.
Max. current	2 A.
Cable	4 x 0.93 mm, 6.6 ±0.3 mm.

2.4.3 Characteristics of the Input Contacts

Switched voltage	5VDC.
Consumption	10 mA.
Cable	4 x 0.34 mm, 5 ±0.5 mm.

Output alarms are always activated on the conditions stated unless requested by customer to operate on other conditions.

Input contacts are designed for remote UPS operation. Use extreme caution when using these contacts so as not to endanger persons or compromise the UPS load.

(This page left blank intentionally)

3.0 Scope

Describes the operator display panel, interface screens, keys, and mimic diagram.

3.1 Operator Interface Keys and Indicators

The operator interface screens contained on the Galaxy 4000 display panel provide an easy to use method to access and control the Galaxy 4000 features.

The Soft Keys are programmed to allow you to scroll up and down through the list of alarms (soft keys #1 and #2). Soft key #3 allows you to delete a specific alarm message. Soft key #4 allows you to examine in further detail a specific alarm message. Although slightly different in operation, the detail key (soft key #4) must be held down to examine the message details. See Figure 3-1.

The four dedicated purpose keys are the main menu, online help, ON (green), and OFF (gray) buttons. For inverter OFF a confirmation will always be requested.

Figure 3-1: Display Panel Keys and Indicators.

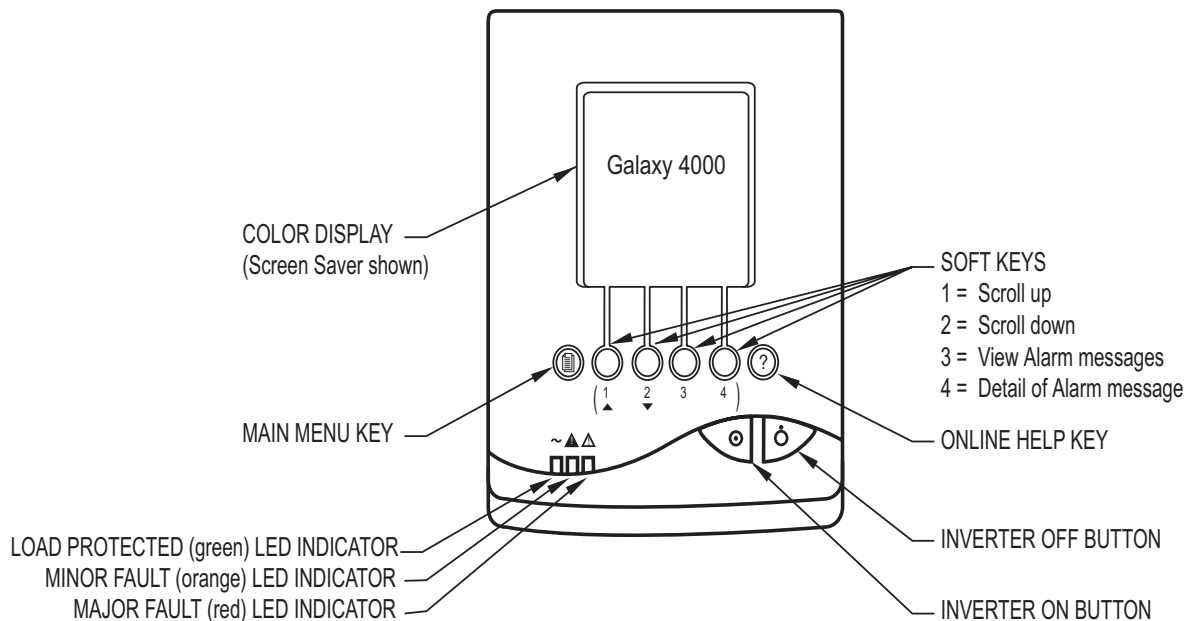

3.1.1 LED Indicator Functions

The three LED indicators (see Figure 3-1) provide the following information as shown in Table 3-1:

Table 3-1: Three LED Indicators.

Green LED		Orange LED		Red LED	
ON	Load on UPS	ON	Minor fault such as:	ON	Major fault such as:
Flashing	Load is on battery power		Loss of AC input power		Internal fault
OFF	Inverter not connected to load		Battery problem		Rectifier fault
			Overload		Inverter fault
			Load on bypass		Bypass static switch fault
			Battery not connected		



IMPORTANT When the Red LED is ON, the load is not protected.

3.1.2 Screen Saver

When the Galaxy 4000 system has been in continuous operation, the operator interface will present a screen saver display. See Figure 3-2.

The product name, "Galaxy 4000", will be moving around the screen to provide an indication that the unit is functional.

Figure 3-2: Screen Saver.

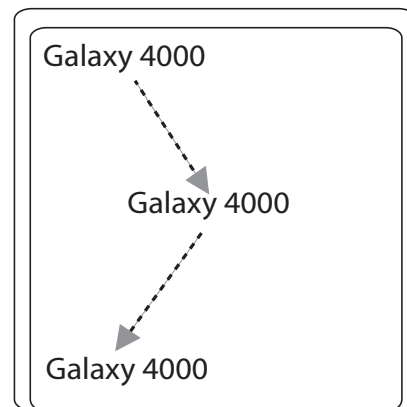

3.1.3 Operational Summary Screen

Pressing any of the keys will cause the unit to provide an operational summary display with the following information. This display will quickly show the operator the time/date, the KVA load on all three phases, as well as the battery level. See Figure 3-3.

Figure 3-3: Operational Summary screen.

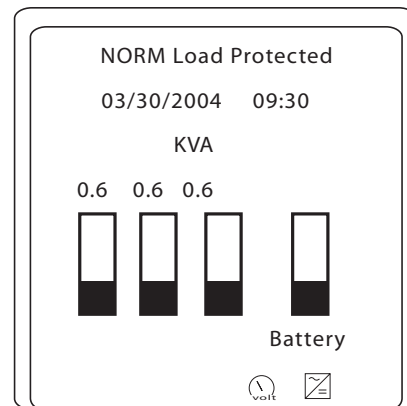

3.2 Display Menu Structure

This display menu structure is provided below for the Galaxy 4000 system in Figure 3-4.

Figure 3-4: UPS Display Menu Structure.

UPS MAIN MENU

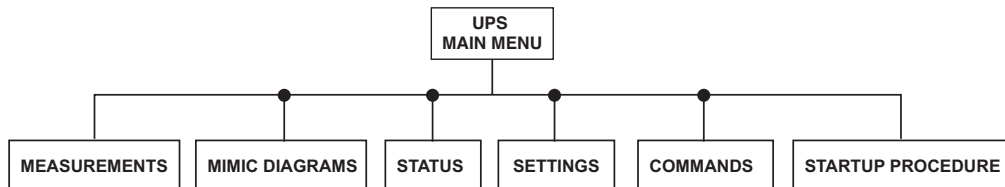

MEASUREMENTS

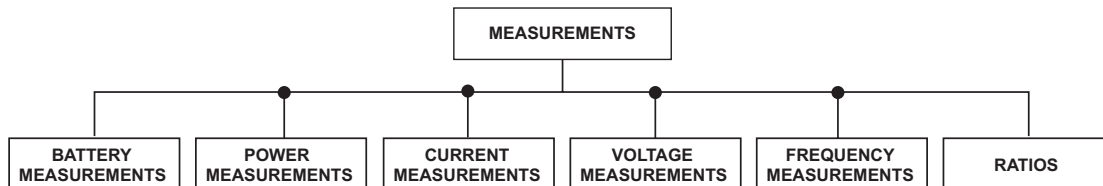

MIMIC DIAGRAMS

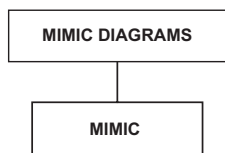

STATUS

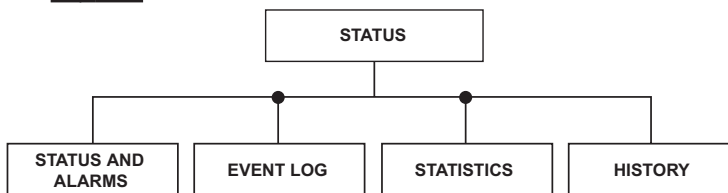

SETTINGS

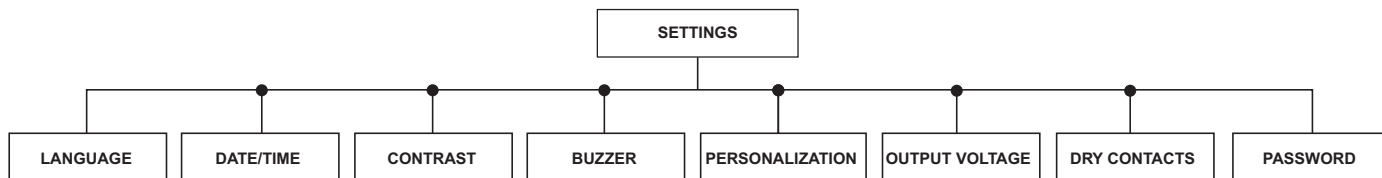

COMMANDS

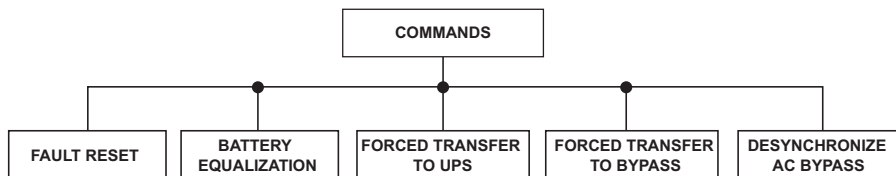

STARTUP PROCEDURE

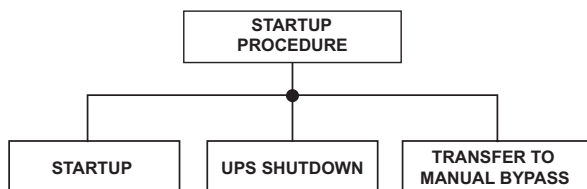

3.3 Main Menu Screen

The Main Menu screen allows the operator to access many displays to monitor the operating performance of Galaxy 4000, obtain alarm information, change operational settings as well as issue software based commands.

The Main Menu conveniently displays groups of items according to function. By using one of the first two soft keys the selection cursor may be moved up and down until the desired display group is selected. Then by pressing the fourth soft key, the selected display (or display group) will be summoned. See Figure 3-5.

Figure 3-5: Main Menu screen.

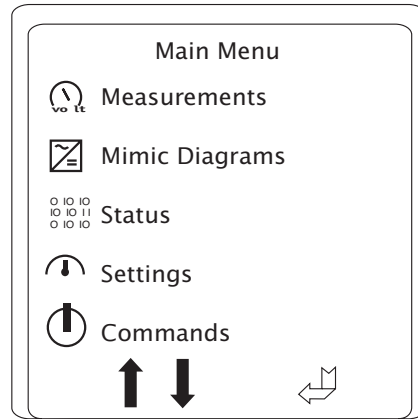

3.4 Measurements

Selecting the Measurements option from the main menu provides the following screen selections: battery, power, current, voltage, frequency measurements, and ratios.

3.4.1 Battery Measurements Screen

The Battery Measurements screen provides a rapid assessment of the available battery voltage, current, battery charge, temperature as well as expected service life. See Figure 3-6.

Figure 3-6: Battery Measurements screen.

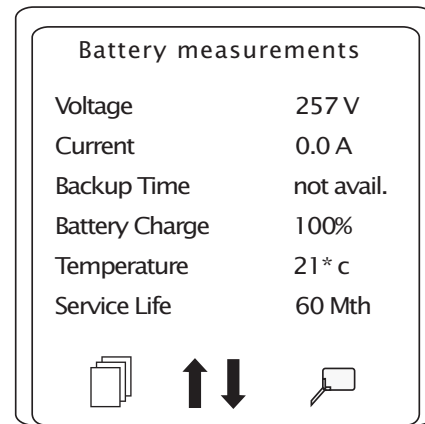

The backup time measurement will be calculated if the following battery parameter identification (BPI) requirements are met:

Required Conditions to Initiate BPI:

- ▶ BPI set to automatic in personalization.
- ▶ Battery charge level = 100%.
- ▶ UPS On-line (Inverter Coupled).
- ▶ Mains 2 within tolerance.
- ▶ Percent load is >15%.
- ▶ Battery temperature 0-40°C (32-104°F).
- ▶ No battery faults.
- ▶ No rectifier or inverter overload condition.

If the above conditions are met and maintained then the UPS will run a successful BPI. A normal BPI will drain the batteries to a level of 80% capacity. When the BPI is completed successfully, the backup time will be displayed when the batteries are 100% charged. If the load does not change by more than ±20%, then a BPI will be run again in one year. Another BPI will run only if, the load changes by ±20% or the BPI is a year old.

If one of the conditions below occurs during the performance of the BPI, the BPI will be aborted.

Factors Leading to Abort a BPI:

- ▶ Inverter to mains 2 source transfer.
- ▶ Load percent drops to <15%.
- ▶ Battery temperature outside 0-40°C (32-104°F).
- ▶ Percent load changes more than +/-5% from starting power level.

- ▶ Battery temperature does not stay within $\pm 10^{\circ}\text{C}$ from the starting temperature point.
- ▶ Communication fault.
- ▶ Input current 0 amps or $> 100\%$ load current.
- ▶ Rectifier or inverter overload.
- ▶ Mains 1 or Mains 2 failure.

In case the BPI cannot be done, a simplified autometer will be used. This autometer will start and display backup time when the batteries are 100% charged. Because the calculation used is more simplified than the one used for calculating backup time using a BPI, these will be less accurate. Therefore it is preferable to use the BPI whenever possible. This provides an option for example, when less than 15% load or cannot run a BPI.



NOTE

Any of the displayed items can be examined further by using the soft key with the double arrows to select the item of interest and then pressing the soft key with the magnifying glass.

3.4.2 Power Measurements Screen

The **Power Measurements** screen displays the load power on each phase in KVA and in KW. Additionally, the AC "normal" (AC N) source is shown with the KVA. See Figure 3-7.

Figure 3-7: Power Measurements screen.

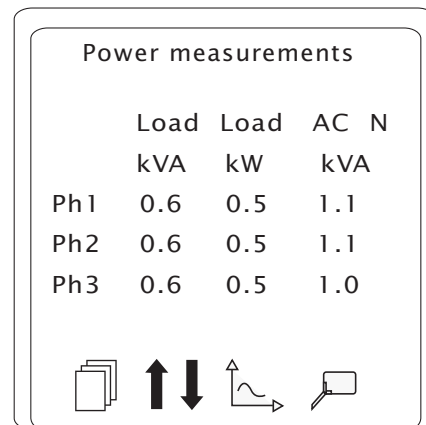

3.4.3 Current Measurements Screen

The **Current Measurements** screen displays the current on the load, AC "normal" (AC N), and AC "bypass" (AC BP) on each of the three phases and neutral. See Figure 3-8.

Figure 3-8: Current Measurements screen.

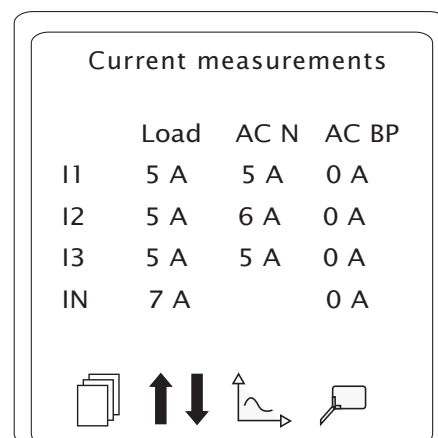

3.4.4 Voltage Measurements Screen

The **Voltage Measurements** screen displays the voltage presently on any one of the input phases (AC N and AC BP) and each phase of the load, as well as the differential voltage as measured between any two phases of the inputs and the load. See Figure 3-9.

Figure 3-9: Voltage Measurements screen.

Voltage measurements			
	Load	AC N	AC BP
V1	120 V	121 V	120 V
V2	120 V	121 V	120 V
V3	121 V	121 V	120 V
U12	207 V	209 V	209 V
U23	207 V	209 V	209 V
U31	207 V	209 V	209 V



3.4.5 Frequency Measurements Screen

The **Frequency Measurements** screen displays the frequency presently on any one of the input lines (AC N and AC BP) and the load. See Figure 3-10.

Figure 3-10: Frequency Measurements screen.

Frequency measurements		
Load	AC N	AC BP
60.0 Hz	59.9 Hz	59.9 Hz

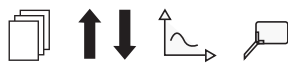

3.4.6 Ratios Screen

The **Ratios** screen displays the crest factor for each phase, the present percentage of load for each phase and for the total unit. Additionally, the load in KVA/KW is provided. See Figure 3-11.

Figure 3-11: Ratios screen.

Ratios		
Crest Factor		%Load
Ph1	1.5	13 %
Ph2	1.5	13 %
Ph3	1.5	13 %
Load	kW/kVA	0.8
kW percent load		12 %



3.5 Mimic Diagrams

The **Mimic Diagrams** screen is unlike any of the other screens we have examined. This screen is actually two screens in one. The top half of the screen contains a single line representation of the current operating condition of the Galaxy 4000 unit. Through the use of color changes in the screen, it will indicate whether the unit is operating normally, is on bypass, or is currently running on batteries. Segments are green when the function is active, orange when not active, and red when a fault has occurred. See Figure 3-12.

The lower half of the screen will show any existing alarm conditions.

Soft Keys

- 1 & 2 Soft keys are now programmed to allow the user to scroll up and down through the list. See Figure 3-12.
- 3 To delete a specific alarm message.
- 4 To further examine a specific alarm message.

The detail key (#4) must be held down to examine the message details. To exit this display, it is necessary to press the **Main Menu** key.

Figure 3-12: Mimic Diagrams screen.

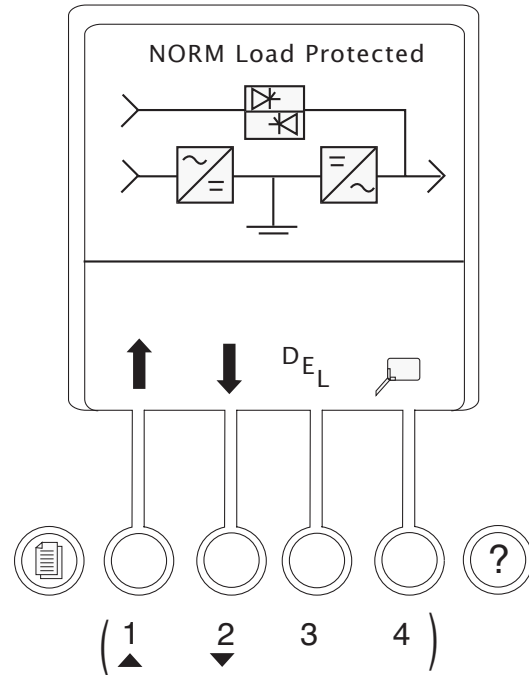

3.6 Status Screen

Selecting the **Status** option from the **Main Menu** provides the following screen selections: Status and Alarms, Event log, Statistics, and History. See Figure 3-13.

Status and Alarms

Provides the user with the present list of alarms and warnings.

Event Log

Provides the user with the history of events with date and time stamp.

Statistics

- Provides total time:
 - on battery power.
 - on AC Bypass (AC BP).
 - on UPS (AC N or battery).
 - with battery temperature (TBatt) >25°C.

History

- Provides history after 60 days for:
 - battery capacity.
 - backup time.
 - % of load.

Figure 3-13: Status screen.

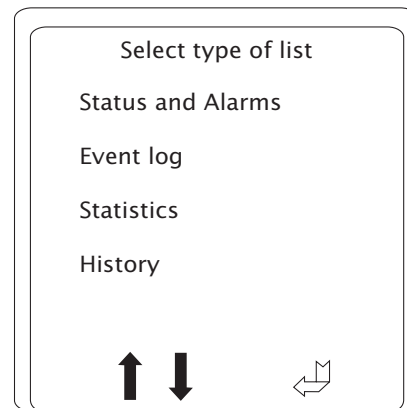

3.7 Settings Screen

The **Settings** screen provides a variety of options for the operation of the Galaxy 4000 system. See Figure 3-14.

The Settings screen provides the following:

Language

With an opportunity for the Galaxy 4000 unit to be located in any country, it is possible to select the language of preference from several options.

Date/Time

Can be set to insure that the time stamps on the event and alarm logs reflect the current local time and date.

Contrast

Allows the contrast of the operator interface unit to be adjusted to maximize its visibility in the current ambient lighting conditions.

Buzzer

Allows the volume of the buzzer to be set.

Personalization

Allows the operator to select any number of operating parameters for the UPS.

Output Voltage

Factory set. Requires a password.

Dry Contacts

Factory set. Requires a password.

Password

Factory set. Requires a password (factory default 000).

Figure 3-14: Settings screens.

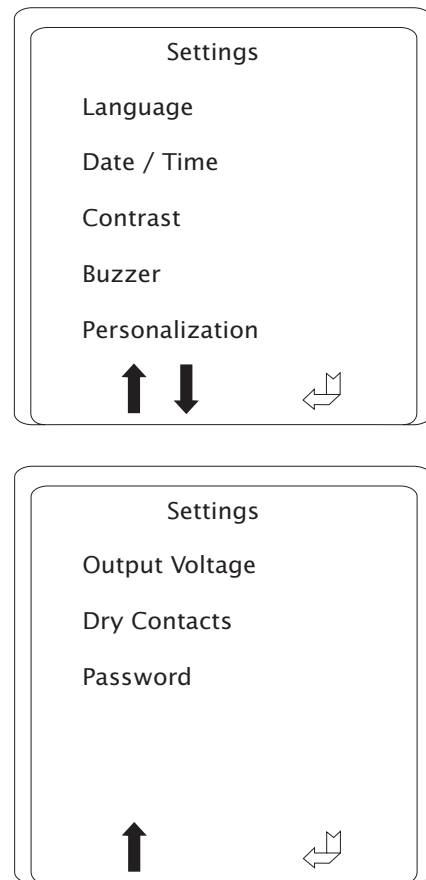

CAUTION

Do NOT adjust any parameters in the personalization section without a clear understanding of the implications to your operation. Should there be any questions about a factory or present setting, please do not hesitate to contact the Customer Support Center at MGE UPS Systems, Inc.

3.8 Commands Screen

The **Commands** screen presents options that impact the operation of the UPS system. Extreme care should be exercised when selecting ANY of these menu options. See Figure 3-15.

The **Commands** screen provides the following:

Fault reset

Allows the user to reset a fault condition.

Battery equalization

Turns the charger on to the maximum battery voltage.

Forced transfer to UPS

Allows transfer to UPS when bypass is not available. Use of this command will drop load.

Forced transfer to BP (Bypass)

Allows transfer to bypass with 100ms break. Use of this command will drop load.

Desynchronize / AC BP

To desynchronize the Inverter from the AC bypass. Transfer inhibit will not allow transfer to and from inverter.

Resynchronize / AC BP

To resynchronize the Inverter to the AC bypass.

Lamp Test

Allows the user to test the backlight.

Buzzer Off

Allows the user to disable the buzzer.

Close AC Bypass SS (static switch)

Closes the bypass static switch. Normally closed.

Open AC Bypass SS

Disconnects the bypass source.

Validate LCM Signalization

Factory set. Requires password.

Inhibit LCM Signalization

Factory set. Requires password.

Figure 3-15: Commands screens.

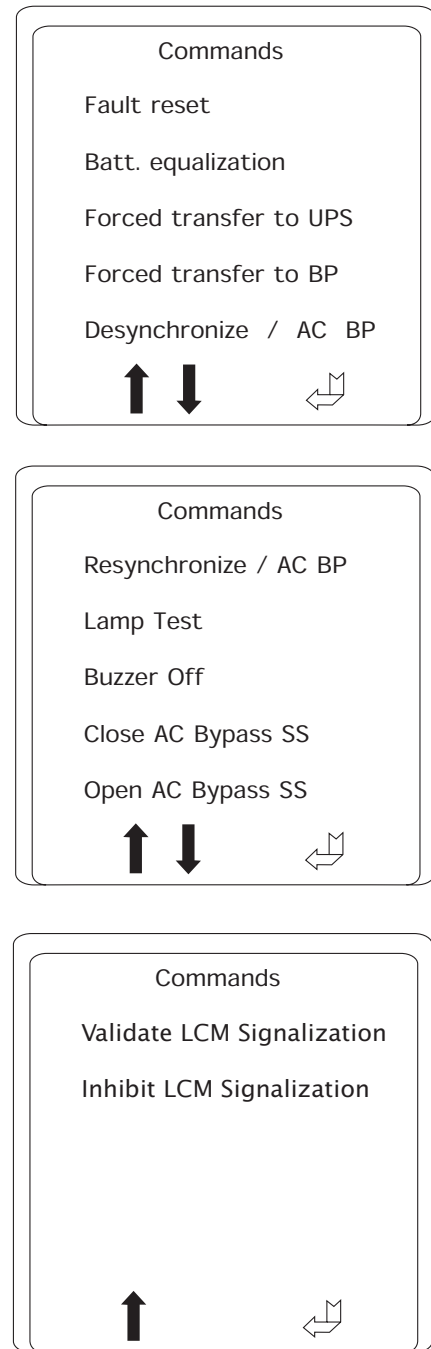

3.9 Startup Procedure Screen

The Startup Procedure screen provides the user general information for startup, shutdown and transferring to manual bypass.

(This page left blank intentionally)

4.0 Scope

Provides startup, shutdown, and normal operation of the Galaxy 4000 UPS. Included are pre and post startup safety checklists.

The Galaxy 4000 system is simple to operate and yet provides a wealth of continuous monitoring and diagnostic features to ensure the proper operation. Operators gain access to information in the Galaxy 4000 system through the display panel. See section 3 for operation of the display panel.

4.1 Preparing for Startup

Before being able to use the display panel to monitor and control your Galaxy 4000 system, a number of items should be verified to insure that all conditions will provide for safe operation. The following check lists are provided to aid in the successful pre and post startup of the Galaxy 4000. They include items to verify prior to applying power, and then tests that should be performed (when appropriate) after startup to verify the health and functionality of all critical modules within the system.

Before starting the Galaxy 4000, read this Installation and User Manual thoroughly. Be certain that you fully understand the operation of the indicators, controls, and operational sequences. MGE UPS SYSTEMS offers professional startup services in most countries. It is strongly suggested that before applying power to your Galaxy 4000, you contact MGE Field Services to properly commission your system.

4.1.1 Pre-Startup Safety Check List

- ▶ Ensure all power and control wires have been properly connected and securely tightened.
- ▶ Check to see that the upstream and downstream protective devices are not tripped, and have been sized properly for the UPS and load requirements.
- ▶ Check that the input voltage is the same as indicated on the UPS nameplate, located inside the door of the Galaxy 4000 UPS.
- ▶ Make certain that nothing is blocking the air intake underneath and around the front bottom of the UPS and that the air exhaust on the top of the UPS is free of all obstructions.
- ▶ If present, check to see that the external optional maintenance bypass circuit breakers CB1, CB2, and CB3 (optional breaker) are in the OFF (open) position.
- ▶ Check to see that the battery disconnect circuit breaker(s) CB1 (in battery cabinet) is in the OFF (open) position.
- ▶ Check to see that the cabinet is resting on its lifting leveler jacks and are not on the 4 casters.
- ▶ Check that the load-circuit breakers (where applicable) are in the OFF position.

Figure 4-1: Galaxy 4000 Device Locations.

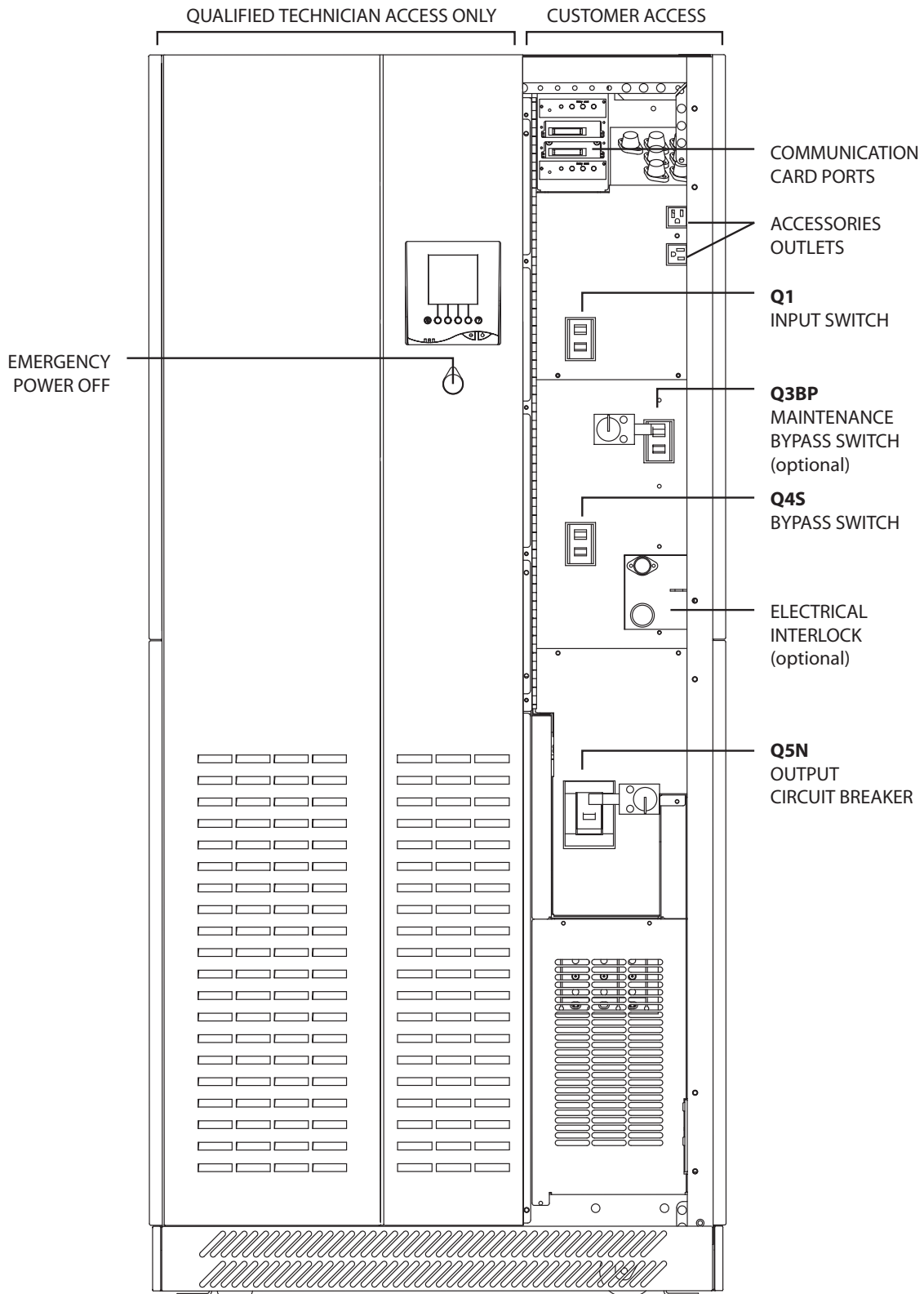

4.2 Normal Startup Procedure

With all of the initial safety check lists verified, the Galaxy 4000 UPS system can now be powered.

The following startup procedure should be performed during the initial startup following installation and commissioning of the system (typically by a MGE Field Engineer), and this sequence should be followed any time that the Galaxy 4000 UPS is being restarted from an off condition (i.e., after the UPS has been powered down by removing the upstream AC input power and opening all the circuit breakers of the UPS). For device locations refer to Figure 4-1.

- a. Apply power to the UPS bypass by closing the upstream circuit breaker supplying Q4S (mains 2).
- b. Apply power to the UPS input by closing the upstream circuit breaker supplying the main AC input Q1 (mains 1).
- c. Close the maintenance bypass switch Q3BP in the UPS cabinet or in an external cabinet if present. Power is now available at the UPS output (the load is energized) via maintenance bypass.
- d. Close the bypass switch Q4S. The static switch will come on-line; the fans will start and the display will illuminate.
- e. Close the output isolation circuit breaker Q5N.
- f. Open the maintenance bypass switch Q3BP in the UPS cabinet or in an external cabinet if present. The load is now supplied via the static bypass.



NOTE

If your UPS configuration does not include the maintenance bypass option, startup requires only closing Q4S and Q5N to supply the bypass source to the attached load.



IMPORTANT

If the UPS is programmed for automatic restart the inverter will automatically start.

- g. Close the input switch Q1. Verify that the following conditions exist:
 - The red “load not protected” LED is on.
 - The rectifier automatically starts.

If either condition is not present, there is a fault. Open Q1 and contact MGE Field Services.

- h. Close the battery disconnect circuit breakers CB1. The batteries are now connected to the battery charger, and have begun charging.
- i. If the UPS is programmed for manual restart, press the “inverter on” green pushbutton.
- j. The UPS will automatically transfer the load to the UPS inverter output. The green “load protected” LED will turn on and remain on.
- k. Close the optional output distribution circuit breakers (if present).



NOTE

If the transfer conditions are not satisfied (bypass AC input source is out of tolerance, or some other reason), a forced transfer is required.

4.3 Post Startup Safety Check List

After initial startup of the system, normal operation should be tested. At the minimum, the following tests should be performed as applicable to your installation.

- ▶ Emergency Power Off (EPO) test.
- ▶ Remote Emergency Power Off (REPO) test (if applicable).
- ▶ Inverter start and stop.
- ▶ Battery transfer test.
- ▶ Maintenance bypass procedure.



CAUTION

As soon as AC input power is supplied to the Galaxy 4000 (customer supplied upstream circuit breaker is in the "ON" position), the load is initially supplied via the "Static Switch". Verify that no error indications are present on the operator interface display panel.

4.4 Shutdown Procedure

Proceed as follows:

1. Press the gray, Inverter OFF button.
2. Confirm by pressing the function key.

The load is no longer protected by the UPS. It is supplied via the bypass.

3. Set the battery circuit breakers CB1 (in battery cabinet) to the OFF position.
4. Close Q3BP, open input switch Q1, bypass switch Q4S, and output breaker Q5N.
5. To completely remove power from the UPS, open Q3BP and open the upstream circuit breakers supplying AC power to switches Q1 and Q4S. Attention: There is no power to the load.

4.5 Shutdown Using EPO

During an emergency situation the UPS and all downstream devices can be instantly shutdown by pressing the red emergency power off (EPO) pushbutton on the front door of the UPS cabinet, or pressing the remote emergency power off (REPO) pushbutton (if applicable) located within the room.



IMPORTANT

Pressing the EPO button disconnects the attached load. The emergency power off (EPO) is to be used during emergency situations only, where a hazard to personnel or equipment exists.

4.6 Recovery from EPO

To recover from an emergency power off press the EPO pushbutton again. Follow the normal startup procedure in Section 4.2.



NOTE

The EPO pushbutton is a latching device. The EPO condition will remain until the EPO button is depressed a second time.

5.0 Scope

Describes maintenance and safety information on servicing batteries for the Galaxy 4000.

5.1 Servicing Batteries

IMPORTANT SAFETY INSTRUCTIONS FOR SERVICING BATTERIES

Servicing of batteries should be performed or supervised by personnel knowledgeable of batteries and the required precautions. Keep unauthorized personnel away from batteries.

When replacing batteries, use the same model and manufacturer of batteries.



CAUTION

Do not dispose of battery or batteries in a fire. The battery may explode. Do not open or mutilate the battery or batteries. Released electrolyte is harmful to the skin and eyes. It may be toxic. A battery can present a risk of electrical shock and high short-circuit current.

The following precautions should be observed when working with batteries:

- ▶ Remove watches, rings, or other metal objects.
- ▶ Use tools with insulated handles.
- ▶ Wear rubber gloves and boots.
- ▶ Do not lay tools or metal parts on top of batteries.
- ▶ Disconnect charging source prior to connecting or disconnecting battery terminals.
- ▶ Determine if the battery is inadvertently grounded. If inadvertently grounded, remove the source of ground. Contact with any part of a grounded battery can result in electrical shock. The likelihood of such shock will be reduced if such grounds are removed during installation and maintenance.

(This page left blank intentionally)

MGE Warranty & Proprietary Rights Statement for Three Phase Products

(Applicable within the United States, Canada and Mexico)

MGE Standard Three Phase Warranty

MGE UPS SYSTEMS, INC. ("MGE") warrants three phase products it manufactures to be free from defects in materials and workmanship for a period of three hundred sixty five (365) days counting from the date of purchase by or for the first end user ("Purchaser"), or, if applicable, the date of MGE's completion of initial startup of the subject product, provided however said warranty shall not exceed eighteen (18) months from the date of delivery of the subject product to Purchaser (the "Warranty Period"). MGE's liability hereunder is limited to replacing or repairing at MGE's factory or on the job site, at MGE's option, any part or parts that are defective and reported to MGE during the Warranty Period. MGE shall have the sole right to determine if the parts are to be repaired at the job site or whether they are to be returned to the factory for repair or replacement. All items returned to MGE for repair or replacement must be sent freight prepaid to its factory. Purchaser must obtain MGE's Return Goods Authorization ("RGA") prior to returning items. The conditions stated herein must be met for MGE's warranty to be valid. MGE will not be liable for any damage done by unauthorized repair work, unauthorized replacement parts, from any misapplication of the subject product, for damage due to accident, abuse, or act of God (such as earthquake, flood, inclement weather, rain or fire), or relating to Purchaser's failure to follow proper environmental conditions for the product.

In no event shall MGE be liable for loss, damage, or expense directly or indirectly arising from the use of or any defects in the subject product, or from any other cause, except as expressly stated in this warranty. EXCEPT AS EXPRESSLY STATED IN THIS WARRANTY, MGE UPS SYSTEMS, INC. MAKES NO WARRANTIES, EXPRESS OR IMPLIED, INCLUDING ANY WARRANTY AS TO MERCHANTABILITY OR FITNESS FOR A PARTICULAR PURPOSE OR USE OR NON-INFRINGEMENT. MGE is not liable for and Purchaser waives any right of action it has or may have against MGE for any consequential or special damages arising out of any breach of warranty, and for any damages Purchaser may claim for damage to any property or injury or death to any person arising out of its purchase or the use, operation or maintenance of the subject product. The warranty stated herein includes parts and labor; however, MGE will not be liable for any labor subcontracted or performed by Purchaser for preparation of the warranted item for return to MGE's factory or for preparation work for field repair or replacement, and MGE will not be responsible to pay any invoice therefore.

This warranty shall be exclusive of any and all other warranties express or implied and may be modified only by a writing signed by an authorized officer of MGE UPS SYSTEMS, INC. This warranty shall extend to the Purchaser but to no one else. Accessories supplied by MGE, but manufactured by others, carry any warranty the manufacturers have made to MGE, and which can be passed on to Purchaser.

MGE UPS SYSTEMS, INC. makes no warranty with respect to whether the products sold hereunder infringe any patent, U.S. or foreign, and Purchaser represents that any specially ordered products do not infringe any patent. Purchaser agrees to indemnify and hold MGE UPS SYSTEMS, INC. harmless from any liability by virtue of any patent claims where Purchaser has ordered a product conforming to Purchaser's specifications, or conforming to Purchaser's specific design.

Purchaser has not relied and shall not rely on any oral representation regarding any products sold hereunder and any oral representation shall not bind MGE UPS SYSTEMS, INC. and shall not be part of any warranty.

There are no warranties which extend beyond the description on the face hereof. In no event shall MGE UPS SYSTEMS, INC. be responsible for consequential damages or for any other damages except as expressly stated herein.

Proprietary Rights Statement

The information in this manual is the property of MGE UPS SYSTEMS, INC., and represents a proprietary article in which MGE UPS SYSTEMS, INC. retains any and all intellectual property rights, including exclusive rights of use and/or manufacture and/or sale. Possession of this information does not convey any permission to reproduce, print, manufacture or have made the article or articles shown herein. Such permission may be granted only by specific written authorization signed by an authorized officer of MGE UPS SYSTEMS, INC.

IBM, PC-AT, ES/9000, and AS/400 are trademarks of International Business Machines Corporation. MGE and MGE UPS SYSTEMS are trademarks of MGE UPS SYSTEMS, INC. Other trademarks that may be used herein are owned by their respective companies and are referred to in an editorial fashion only.

For Three Phase Warranty outside of the United States, Canada and Mexico, refer to Three Phase International Warranty.

January 2005 Rev C00

Warranty and Product Registration

Thank you for choosing MGE UPS SYSTEMS, INC. for your power protection, distribution, and quality requirements. We are pleased to have you join our increasing family of users.

In order to maximize the value you receive from this product, and to ensure that you are kept informed of product or software updates, we recommend that you take a few minutes to register your new purchase. You may register online at the URL noted below. Should you not have Internet access, you may mail or fax this form back (attn: Warranty Registration) as indicated at the bottom of the page.

Register your product at: <http://www.mgeups.com/email/warranty/menu.htm>

Please be prepared with the following information to register and validate your product's warranty, keep informed on software and product updates, and register your extension "Warranty+" if purchased with the product.

User Information

Last name _____
First name _____
Company name _____
Address _____
Zip code _____
City _____
State/Province _____
Country _____
Tel _____
Fax _____
Email _____

Product Information

Model _____
Serial Number _____
Date of purchase _____

Warranty Extension (Warranty+)

I have purchased a warranty extension (Warranty+)

Reference: _____ Contract Number: _____

Thank you from all of us at MGE.

MGE UPS SYSTEMS, INC., 1660 Scenic Avenue, Costa Mesa, CA 92626, USA
Tel: 714-557-1636 Fax: 714-557-9788

41-000154-53 Rev B02 8/2005

MGE Customer Care Center – Three Phase Products

Technical Support and Product Services



Technical questions? If you encounter a problem while following the instructions in this manual, or have questions about the operation, repair, or servicing of your equipment, please direct calls to MGE UPS SYSTEMS, INC. Customer Care Center or visit our web site www.mgeups.com for complete service information.

To insure that your questions are correctly answered, please obtain the serial number of the unit and include them in any discussions or correspondence.

Serial number: _____

Who To Contact

Customer Care Center: **1-800-438-7373** (Hours: 24/7)

**Customer FAQ
or International calls:** **1-714-557-1636**

Commitment: MGE UPS SYSTEMS, INC. is committed to providing easy to access factory trained experts that will provide responses to any questions that you might have.

Scheduling Field Service Engineer Support

Scheduling of the MGE Field Service Engineers typically should be done 7 to 10 days before they are required on-site. If the startup of the product is critical to maintaining your schedule, please call the MGE toll free telephone number at **1-800-438-7373** for assistance.

Return Policy for Repair of Three Phase Products (RGA)

Should you require factory service for your equipment, contact MGE Customer Care Center and obtain a Return Goods Authorization (RGA) prior to shipping your unit. Never ship equipment to MGE without first obtaining an RGA number.

Date: _____

RGA Number: _____

Contact Name: _____

CAUTION: Record All Serial Numbers!

RECORD ALL SERIAL NUMBERS FOR THE GALAXY 4000 AND ACCESSORIES.
THESE SERIAL NUMBERS WILL BE REQUIRED IF YOUR SYSTEM NEEDS SERVICE.
KEEP THIS MANUAL IN A PLACE WHERE YOU CAN REFERENCE THE SERIAL NUMBERS
IF SERVICE IS REQUIRED!

UPS SERIAL NUMBER: _____

BATTERY SERIAL NUMBER: _____

AUXILIARY SERIAL NUMBER: _____

ADDITIONAL SERIAL NUMBERS:

_____	_____
_____	_____
_____	_____
_____	_____
_____	_____
_____	_____

NOTE:

Glossary

Term used	Definition / Meaning
@	At.
/	And/or.
+/-	Plus or Minus.
≤	Equal to or less than.
#	Number.
°C	Degree Celsius.
°F	Degree Fahrenheit.
∅	Phase angle.
Ω	Ohm; unit of resistance.
®	Trade Mark.
2nd	Second.
ABC	Normal sequence of phases in three phase power.
AC or ac	Alternating current, also implies root-mean-square (rms).
Ambient Temp.	Temperature of surrounding air.
Ambient noise	Acoustical noise of surrounding environment.
ANSI	American National Standard Institute.
AWG	American Wire Gauge. A standard unit for measuring wire cross-sectional area.
Breaker	Electrical circuit interrupter.
BTU or Btu	British thermal unit. Defined as the amount of heat required to raise the temperature of one pound of water by 1°F.
BYPASS mode	Load is powered by the bypass input line through the static switch.
Carrier	The company or individual responsible for delivering goods from one location to another.
CB	Circuit breaker.
CB1	Battery disconnect circuit breaker.
Conduit	A flexible or rigid tube enclosing electrical conductors.
Current rating	The maximum current that a conductor or equipment can carry reliably without damage.

dB	Decibels.
dBA	Decibel Adjusted.
DC or dc	Direct current, or voltage.
Digital Meter	The LCD display on the front panel of inverter system.
Earth ground	A ground circuit that has contact with the earth.
Electrician	Refers to an installation electrician qualified to install high-energy electrical components in accordance with national and local codes and regulations. Not necessarily qualified to maintain or repair electrical or electronic equipment. Compare to Technician.
EPO	Emergency Power Off. Used to switch all UPS/critical power OFF. For emergency power shutdown only.
Frequency slew rate	The change in frequency per unit of time. Given in term of Hz per second (Hz/sec.).
GND	Electrical ground.
Hz	Hertz, frequency measurement unit, 1Hz is one cycle per second.
Inverter mode	See “on-line” mode.
I	Current.
IEC	International Electrotechnical Commission.
IEEE	Institute of Electrical and Electronic Engineers.
Input branch circuit	The input circuit from the building power panel to the equipment.
Inverter	An electrical circuit that generates an AC voltage source from a DC voltage source.
IGBT	Insulated gate bipolar transistors.
I/O	Input/Output.
I/T or IT	Information Technology.
KVA	KiloVolt-Ampere; is equal to 1000 Volt-Ampere.
KW	True power. Kilo-Watt = 1000 Watt.
L	Line.
LCD	Liquid-Crystal Display.
LED	Light Emitting Diode.
Mains or Mains 1	Main AC input source.
Mains 2	Bypass AC input source.
mA	Milliampere.
MAX.	Maximum.
MCM	Thousand circular mil; standard wire sizes for multiple stranded conductors over 4/0 AWG in diameter. M is from Roman numerical system indicating 1000.

Module	Refers to individual power inverter module.
N	Neutral.
NC	Normally closed.
NO	Normally open.
NEC	National Electrical Code.
NFPA	National Fire Protection Association.
PN	Part number.
On-line mode	Inverter output power is the primary energy source to load.
OSHA	Occupational Safety and Health Agency.
PCA	Printed circuit assembly.
PCB	Printed circuit board.
PWM	Pulse Width Modulation.
Q1	UPS input isolation switch.
Q3BP	Optional maintenance bypass switch.
Q4S	UPS bypass switch.
Q5N	UPS isolation circuit breaker.
Remote Emergency Power Off	A switch used for shutting down electrical equipment from a location away from the equipment.
REPO	Remote Emergency Power Off.
SCR	Silicon controlled rectifier.
Shipping damage	Any damage done to an article while it is in transit.
SCR	Silicon controlled rectifier.
Shipping Pallet	A platform on which articles are fixed for shipping.
Static Transfer	A solid state switching mechanism electronically controlled to pass AC power directly from the utility to an output load.
Technician	Refers to an electronic technician qualified to maintain and repair electronic equipment. Not necessarily qualified to install electrical wiring.
Test connector	DB-9 type connector on the LCD panel allowing MGE UPS SYSTEMS Customer Support Service technician to access programmable and diagnostic features of the system.
UL	Underwriter's Laboratories, Inc.
V	Volts
VA	Volt-amperes, unit for apparent power measurement, equal $V \times I$.
VAC	Voltage of AC type.
Vdc	Voltage of DC type.

(This page left blank intentionally)

Reorder Form



**1660 Scenic Avenue
Costa Mesa, CA 92626**

Use this form to report any errors, omissions, or other problems you have experienced, or to order additional hardcopies of this document. A free copy of this document may be downloaded from the proprietary MGE Rep Web site. Please contact your MGE UPS SYSTEMS, INC. Representative for assistance.

NAME _____

COMPANY _____

STREET ADDRESS _____

CITY _____ STATE _____ ZIP _____

I would like to order _____ (quantity @ \$75.00 each) additional copies of the:

Galaxy 4000

40 - 75KVA

Installation and User Manual

86-173010-00 A00

I would like to report the following problems with this document:

Contact MGE

United States

MGE UPS SYSTEMS

1660 Scenic Ave.
Costa Mesa, CA 92626

Tel: (714) 557-1636
Fax: (714) 557-9788
email: info@mgeups.com
www: mgeups.com

Canada

MGE UPS SYSTEMS

#9, 2789 Thamesgate Drive
Mississauga, ON L4T 4E8

Tel: (905) 672-0990
(877) 672-0990
Fax: (905) 672-7667
email: info@mgeups.com
www: mgeups.com

**Latin America and
Other International**

MGE UPS SYSTEMS

1660 Scenic Ave.
Costa Mesa, CA 92626

Tel: (714) 513-7831
Fax: (714) 434-0199
email: info@mgeups.com
www: mgeups.com

M G E
UPS SYSTEMS